

## Características

- 1 Olhal içamento
- 2 Alavanca Acionamento de Descarga
- 3 Abertura da Descarga Lateral
- 4 Calha de Descarga
- 5 Placa de Identificação

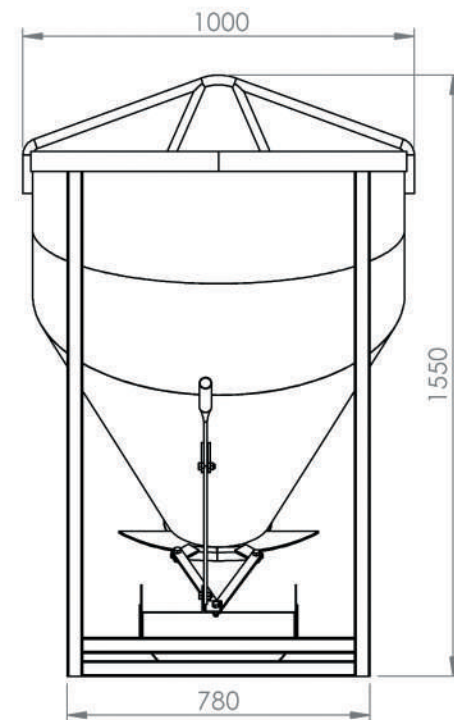

Acompanha Manual Técnico, Memorial de Cálculo e ART

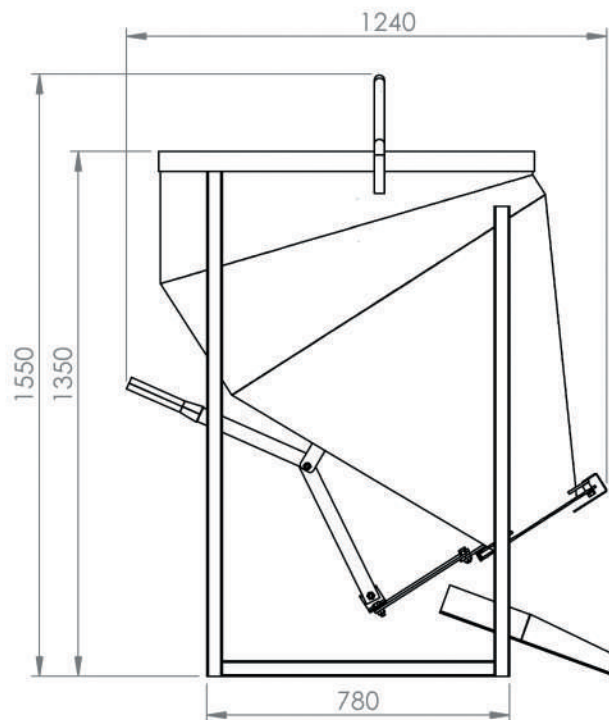

Medidas para Transporte:  
C1240xL1000xA1550

## 5117 BALDE DE DESCARGA LATERAL

Capacidade  
500 Litros

Carga  
1175 Kg

Peso  
92 Kg

Acabamento  
Pintura Eletrostática

Cor  
Laranja

Matéria Prima  
Aço

ART - PROJETO E FABRICAÇÃO VINCULADO AO CREA

