

**EMPILHAMENTO MÁXIMO: 03 GAIOLAS**

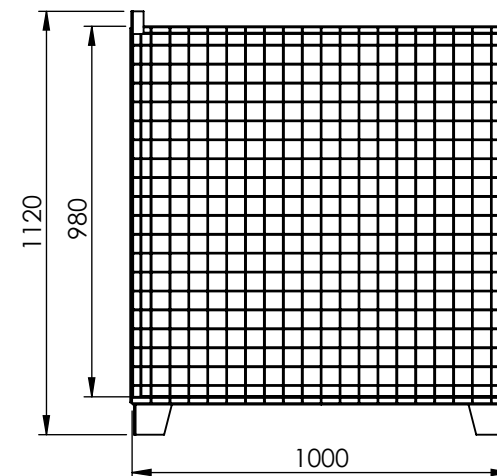
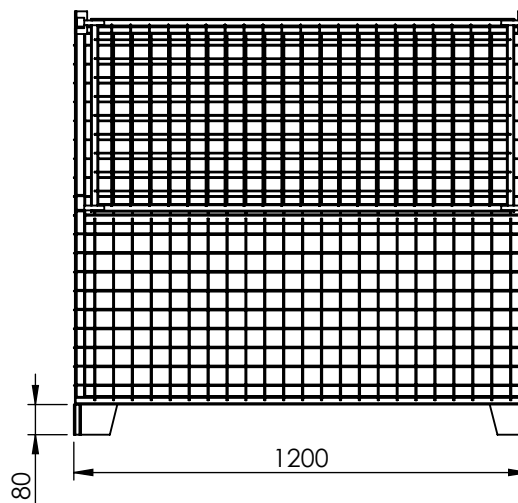
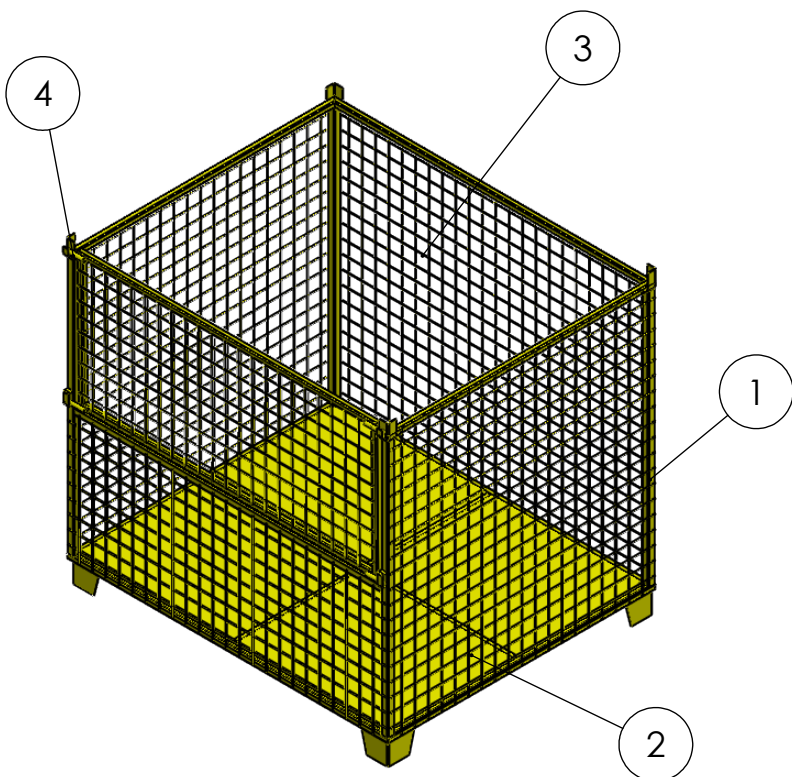

1	ESTRUTURA	TUBO ESTRUTURAL
2	FECHAMENTO FUNDO	CHAPA AISI 1020
3	FECHAMENTO	TELA SOLDADA
4	PORTA	AÇO ESTRUTURAL

10216	<b>GAIOLA ARAMADA 1,0 X 1,2 X 1,0</b>	Capacidade de Carga	Acabamento: <b>PINTURA ELETROSTÁTICA</b>	
Engenheiro	<b>Leandro De Souza Santos</b>	<b>CREA: 035970-7</b>	<b>250 kg</b>	Cor: <b>AMARELO-SEGURANÇA</b> Peso: <b>43 kg</b>