

**PEÇAS APENAS ENCAIXADAS**

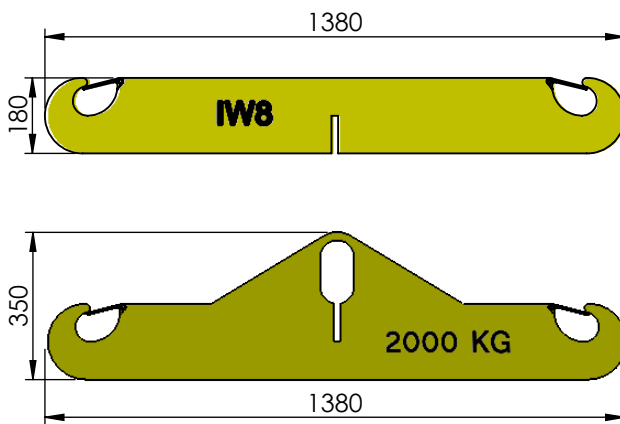

**DIMENSÕES PARA TRANSPORTE**

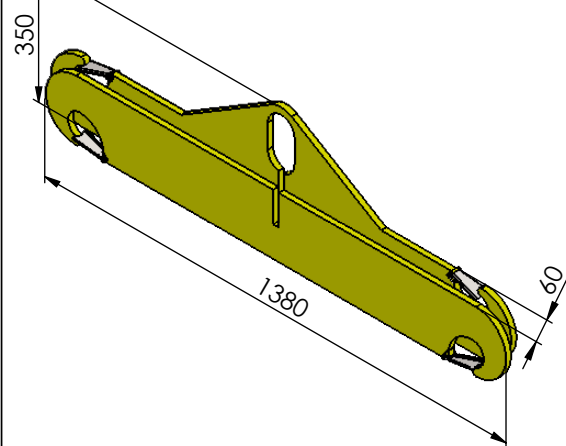

1	ESTRUTURA	CHAPA EM AÇO
2	TRAVA	COM MOLA DE RETORNO

<b>11089</b>	<b>BALANÇIM TRAVESSA BIG BAG DESMONTÁVEL COM TRAVA</b>	Capacidade de Carga	Acabamento: <b>Pintura Eletrostática</b>
Engenheiro	<b>Leandro De Souza Santos</b>	<b>2000 kg</b>	Cor: <b>Amarelo Segurança</b>
	<b>CREA: 035970-7</b>		Peso: <b>62 kg</b>